

USER MANUAL

ABISOFIX



Dear Customer,

You have just purchased a FTM Technologies product. We thank you for your confidence. Please read this manual carefully before using your equipment.

For any information, contact us:

FTM Technologies

78, rue Raymond Poincaré
92000 Nanterre, FRANCE

info@ftm-technologies.com

Tél : + 33 1 40 86 00 09

Fax : + 33 1 40 86 16 45

We reserve the right to make technical changes without notice.

Safety Hints

Please read through the operating instructions thoroughly before using the Abisofix.

Following these instructions will avoid danger and achieve the best results from your Abisofix.

- Check the cable and plug each time before using the wire stripper.
- Repairs to the cable and plug should be carried out by an expert.
- Do not hold down the on/off button while inserting the plug into the socket.
- The unit must not be used when wet or in damp conditions.
- The operator must take particular care when operating the unit if he or she has long hair or is wearing jewellery. do not operate wearing loose fitting clothing.
- Before removing the end housing cap (2) with the plastic (Plexiglas) safety cover (1) ensure that the plug is out of the socket. Always re-tighten loosened parts after making adjustments. Before switching on again, re-assemble the end housing cap (2) and the plastic safety cover (1).
- The Abisofix operates using a protective low voltage supply at 16-40 Volt DC.
- Normally this voltage is produced by a power-supply unit which has to conform to protection standards class III. Never connect the Abisofix directly to the mains, always plug into the power-supply unit.
- When using the Abisofix always wear protective goggles.

Operating Instructions

The Abisofix is connected to your mains supply via a power-supply unit. We recommend the use of the NE30P power supply to achieve best stripping results. Your mains supply must fit with the voltage and cycles of the power-supply. Whenever you connect the Abisofix with your power-supply unit take care to ensure that the + symbol on the plug corresponds with the + symbol on your power-supply unit. Otherwise the cutting knives will rotate in the wrong direction.

Dismantling and assembling the Stripping Head: follow these safety hints. Always disconnect the main plug before making adjustments to the Abisofix, remove the end housing cap (2) from the body by turning anti-clockwise. Insert a screw-driver through one of the ventilations slots(11) and prevent the motor shaft from turning. With the other hand turn the stripping head to the right (left hand thread!) and remove it assembling the stripping head on the threaded shaft centrally and turn to the left until it stops. Make sure it is tight. The stripping head should run centrally and without vibrations, adjust if necessary.

Abisofix Operating Instructions

Models 1,3 and 5

Take the Abisofix in your hand and insert the cable or stranded wire into the middle of the stripping head as far as you wish to remove the insulation. Operate the push button (10) and slowly withdraw the Abisofix while the motor is still running. If all the insulation is not removed, better stripping is achieved by a repeated back and forth movement.

The power supply NE21 has a variable speed setting which can be set depending on the insulation quality and the wire strength. If, in spite of the correct speed setting, the wire is severely damaged we recommend the use of the "LM" type stripping head.

Models 1LM, 3LM, 5LM

In principle the operation of these models is the same as for models 1,3 and 5 with the additional features of:
Length limiting "L" and knife limiting "M"

Adjustment of the "LM" models :

Remove the end housing cap (2)

Important: remember to follow the safety hints.

"L": the length limit can be set by means of the locking screw (5) between a required stripping length of (3-40 mm). for stripping lengths longer than 40 mm, remove, the length limit as follows:

For models 1LM, 3LM and FML3 loosen the stripping head from the motor, remove the locking screw (5) and push it out of the hollow shaft.

On models 5LM and FML 5 the length locking screw can only be removed from above.

If the length limiting stop does not pass through the cutting knife opening, proceed as follows: make a mark on the adjusting ring(6). Loosen the three screws (7) and turn the adjusting ring(6) clockwise –this will give a larger opening between the cuttingknives.

Now the length limiting stop can be pushed out. After removing the length limiting stop turn the adjusting ring(6) up to the mark that was made and re-tighten the screws (7).

"M" To set the knife opening to suit a particular wire diameter, insert a sample of the wire into the opening between the Abisofix knives. Close the knife opening manually whilst turning on of the flyweight (9) until the knives touch the wire. Maintain this position and turn the three grub screws (8) to the right until they lie against the pin of the fly weight. Check again to make sure that all the grub screws (8) are lying uniformly. Replace the end housing cap (2) and carry out a strip test. If the operation does not remove all the insulation, pull out the mains plug and turn the three grub screws (8) a little to the left.

If the operation bites into the wire turn to the right. With some practice, adjusting to different wire diameters becomes easy.

Model S HM–For the stripping of insulation on connector pins down to "zero" distance.

Select the optimum speed on the NE 42 B power supply unit. When stripping move the Abisofix back and forth. Due to the specially shaped knives, insulation can be removed very close to the component ("zero distance").

Models FML3 and FML5–for the removal of insulation sleeving on single and multi-stranded wires: operate in the same way as for models 1LM, 3LM and 5LM. take care that the insulation has been removed first before you withdraw the Abisofix. The stripping process should take place at high speed. Trying a sample piece of material first is advisable. Adjust in the same way as for models 1LM, 3LM and 5LM.

Models AK1 to AK8–For the stripping and cleaning of connector pins in close proximity to one another. Assemble the AK head to the Abisofix motor. Operate the push-button and push the Abisofix slowly forward until the required stripping length has been reached.

For more powerful stripping and the removal of contaminations move back and forth several times. The small cutting knives are set for only one pin thickness, they can be adjusted slightly. To adjust, insert a pin, that requires stripping, through the hole in the spindle and the clamping sleeve, then turn as far "opened" or "closed" as is necessary. Note: Clean the 4 knives of accumulated waste whenever necessary.

Model F–For the stripping of flat copper strips and general milling tasks (e.g. removal of copper beads from motor lamination stacks). Having achieved the correct speed, apply slight pressure and remove the insulation. When material greater than 18 mm needs to be stripped, stagger the operation.

Model V–For the twisting of stranded wire and insulated wire. Pass the V head over the stripped material and slowly withdraw the Abisofix, Select a higher speed for thinner material.

Model VH–For wire twisting. Form an eyelet with the 2 (or possibly more) wires.

Hand the hook in the wire eyelet and with slight back-pull produce the required twisted length.

Important: Select a low speed for thin wires otherwise the wire will be destroyed.

Note: It is possible to remove the isolations of twisted wires using a stripping head.

Bench Fixture Type TP:

The Abisofix is secured using a bench clamp, to the operators bench or table.

Switching on and off is carried out by operating a pneumatic pedal. This allows the operator both hands free to carry out the stripping operation. This greatly improves productivity where mass production is carried out. We advise using stripping heads type "LM" During operation take note of the following: should the Abisofix start without having operated the pedal, pull of the tube connected to the pedal. Then depress the pedal and keeping

the pedal depressed push the tube back on to the pedal. This creates a slight vacuum and the Abisofix will then operate correctly.

Abisofix Motor AMO with hollow shaft Type ADBW

The motor for the Abisofix can be supplied as a separate item.

In the ADVW version it has a hollow shaft. This enables the wire to be passed through the Abisofix. Because of this intermittent stripping can be achieved at varying lengths without cutting the wire so as to achieve taps.

Tools

All cutting knives, heads and tools offered are interchangeable at will.

You therefore have a stripping tool which has multiple applications. For safety reasons, only tools recommended by the manufacturer should be used.

Replacement knives and other spares are available for all models. In the event of wear we advise an overhaul of the whole device or the stripping head in the factory. There, worn knives can be reground.

Cleaning

Deposits of dust inside the Abisofix motor and on the knives should be blown away with oil free compressed air. Never oil the cutting knives.

Maintenance

Through the commutator slots it is possible to see the commutator sparking. If there is excessive sparking, immediately switch the unit off to avoid extensive damage. Checking the unit and possibly replacing the carbon brushes should be carried out by a qualified electrician. In the event of severe damage, return the unit to the servicing agent.

The Abisofix has been tested in accordance with VDE 0740 part I and 1A1, EN294, EN89/392EWG and EN89/336EWG.

Provided the Abisofix wire stripper has not been miss-used we give a 6 months warranty from the date of purchase. Parts which are subject to normal wear and tear are not covered by the warranty.

The maximum noise level at a distance of 0,5 m is 74dB(A). When working under normal conditions the noise level is negligible.

Parts List

- 1 Plastic (Plexiglas) safety cover
- 2 End housing cap
- 3 Stripping head
- 4 ABISOFIX motor
- 5 Length limiting locking screw
- 6 Adjusting ring (aluminium)
- 7 Adjusting ring screws (3 off)
- 8 Knife limiting threaded stud (3 off)
- 9 Flyweight (3 off)
- 10 On/off button
- 11 Ventilation slots (for fan)
- 12 Ventilation slots (for carbon brushes)

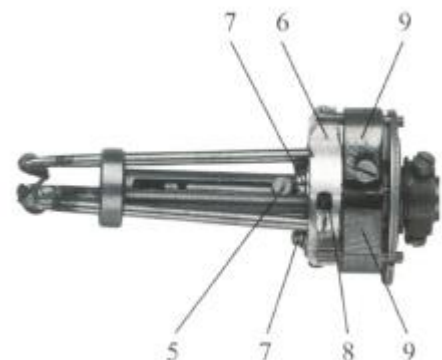
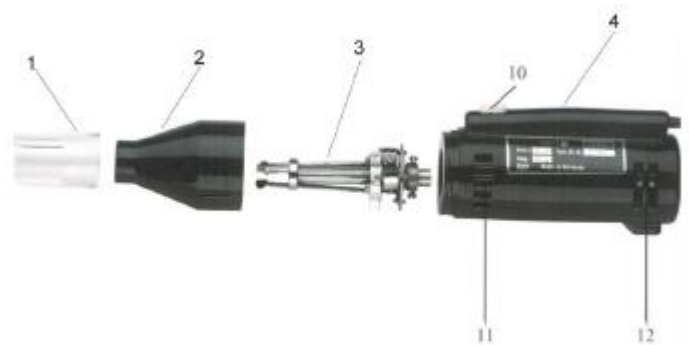

Technical Data:

Voltage :10-40 V DC
Current :1 A
R.P.M :0 –20 000
Diameter :45 mm
Length :180 mm
Weight :450 gr.