

## Standard fume cabinets



Fume cabinets are strongly recommended for applications using hazardous and/or volatile products. When air needs to be confined :

- Solvent cleaning (MEK, acetone...)
- Fumes emanating from machines,
- Aerosol application,
- Handling chemicals,
- Varnishing or potting,
- Tinning
- Application giving off very fine particles (<0.3m microns)
- Etc.

Our standard, removable and easy-to-move cabins can be installed on a desk and receive a retention bin for hazardous products (optional).

Equipped with an extraction unit in single-station version or two units in double-station version, they allow two configurations :

- Filtration of pollutants for internal recirculation of air
- External discharge by connecting a drain hose to the back of the booth

As an option, a more powerful motor (600 m<sup>3</sup>/h) can be proposed for specific needs (dust filtration and/or external discharge)

Made of aluminum, melamine and 6 mm tempered glass, they guarantee robustness and durability in workshops and laboratories.

Our standard hoods are available in pyramidal (HI7VP) or straight (HI5VP) versions.

## Single pyramidal cabins

### HI7VP

Pyramidal hood with a hand clearance of 200 mm

Allows operating above the product thanks to the glass protection

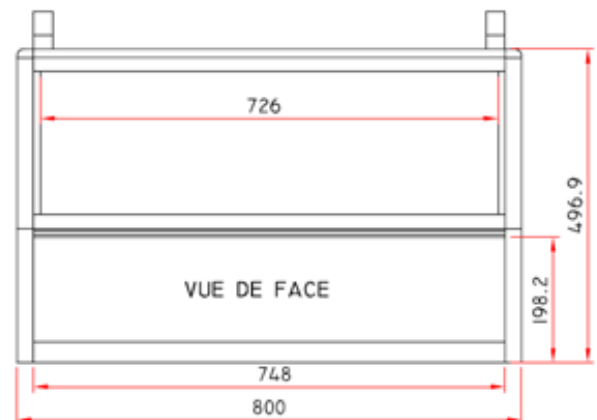
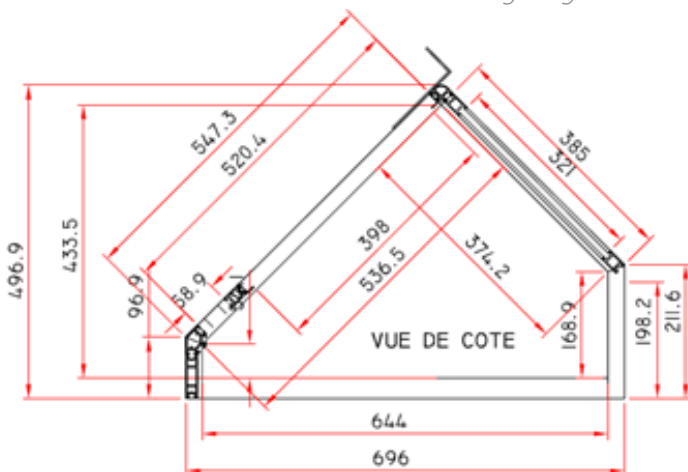
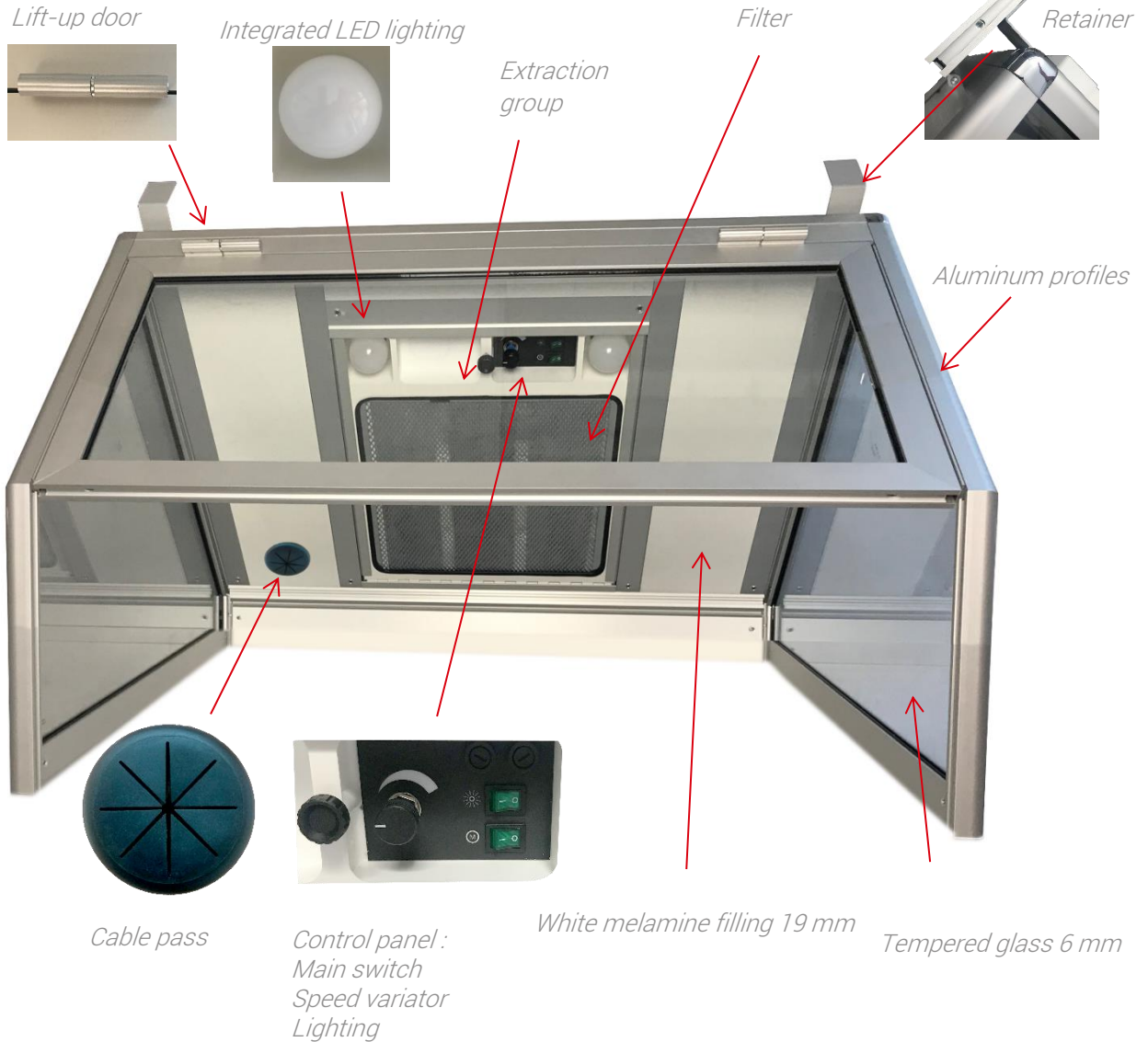

## HI7VPR

Surelevated pyramidal hood offering a hands clearance of 340 mm  
Allows operating above the product thanks to the glass protection  
Lift-up door

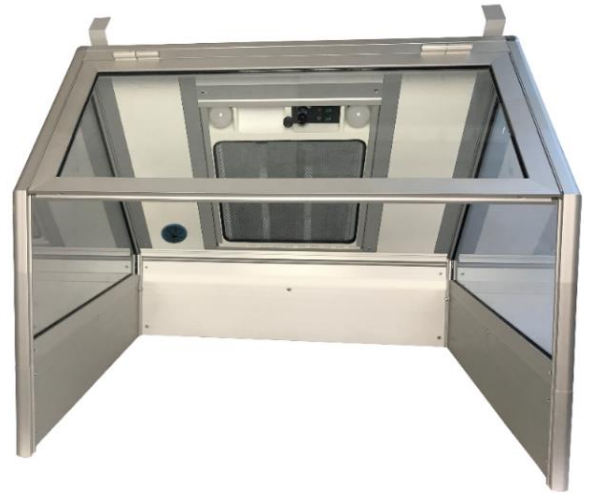

## HI6VP

Surelevated pyramidal hood offering a clearance hands 340 mm  
Allows operating above the product thanks to the glass protection



## Single straight cabinet

## HI5VP

Open cabinet  
Width 800 mm



## HI5VPC

Cabin with 2 panel sliding glass door or teflon bearings  
Width 800 mm



## HI5VPP

Cabinet lift-up door allowing a 200 mm hand clearance  
Width 800 mm

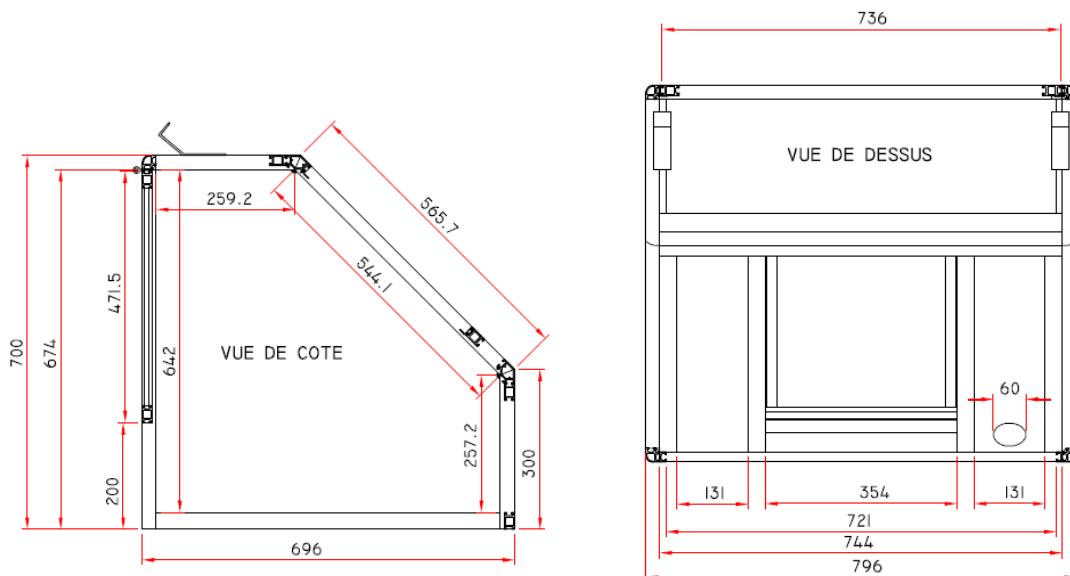

## Multi-station straight cabinet

### HI5VP double

Open cabinet with two suction units  
Width 1572 mm

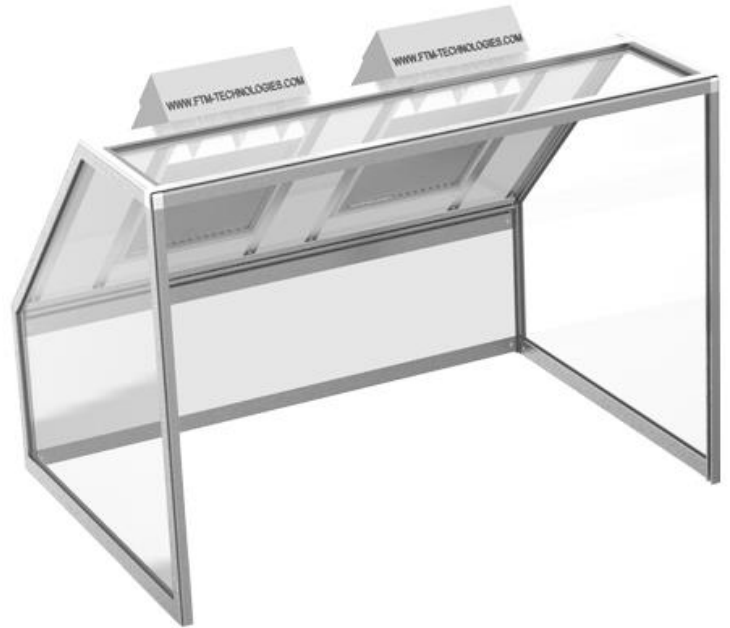

### HI5VPP double

Cabinet with two suction units with lift-up doors, 200 mm hand clearance  
Width 1572 mm



## Options



Boosted unit

Maximum flow 600 m<sup>3</sup> / h (instead of 450m<sup>3</sup>/h)



White lacquered steel retention tank

Dimensions : 740 X 650 X 20 mm



Workbend for single cabinet

RESITOP High thermal resistant laminate top  
Thickness 40 mm

Overall dimensions : 1200 X 750 X 900 to 940 mm

With set of 4 adjustment cylinders



Suction box for HEPA filtration

HEPA H14 filter allowing a maximum 0.005%  
of 0.1 micron particles to pass

Nominal flow : 150 m<sup>3</sup>/h

Dimensions : 420 x 341 x 146 mm





Cabin type	Pyramidal-shaped		Straight				
	Single		Single			Double	
Reference	HI7VP	HI7VPR et HI6VP	HI5VP	HI5VPC	HI5VPP	HI5VP Double	HI5VPP Double
External dimensions L x H x P	800 x 560 x 700	800 x 574 x 700	800 x 700 x 700			1572 x 700 x 700	
Door	Lift-up	Lift-up for HI7VPR	-	Sliding	Lift-up	-	Lift-up
Hands clearance (mm)	200	340	674	-	200	674	200
Number of suction groups	1	1	1	1	1	2	2
Maximum flow (m <sup>3</sup> / h)  (* with boosted group option)	50 to 450/600*	50 to 450/600	50 to 450/600	50 to 550/600*	50 to 450/600*	50 to 900/1200*	50 to 900/1200*
Light flow	940 Lm	940 Lm	940 Lm	940 Lm	940 Lm	1880 Lm	1880 Lm
Net weight (kg)	27	30	35	38	38	64	70
Packing weight in kg	37	40	45	48	48	74	80

## Technical data

Technical data of the suction group	
Variable flow	50 to 450 m <sup>3</sup> /h (600*)
Power	80 W (110 W *)
Mains supply	230 V / 50 Hz
Noise at 1m	60 dB(A)
Maintenance	Periodic change of the filter
Outer rejection	Possible, Ø125 mm

(\* with boosted group option)

## Choice of filters

Reference	Designation	Classification
FPF1	Protection pre-filter (pack of 10)	G3
PF3	Protection pre-filter (pack of 10)	M5
FPP1	Dust filter for external rejection	G4
FAP1	Particle filter for internal recycling	M5
FCP1	Activated carbon filter (solvent, gas and fume recycling)	N/A
FCP1 min	Mineral activated carbon filter for acetone	N/A
FCP1 blend	Activated carbon filter combined with potassium permanganate (Formol and other products)	N/A
FCP1-FT H2SO4	Active carbon filter impregnated with sulfuric acid for alcali adsorption	N/A
FCP1-FT KOH	Activated carbon filter impregnated with potash for acid adsorption	N/A
FHP1	High Efficiency Particulate Air filter	H14