

Setting PC3N

FTM TECHNOLOGIES has developed a new system, which can be sold as a kit, which fits over the pliers PC3N. This system allows the control and the adjustment of strip length.

Assembly:

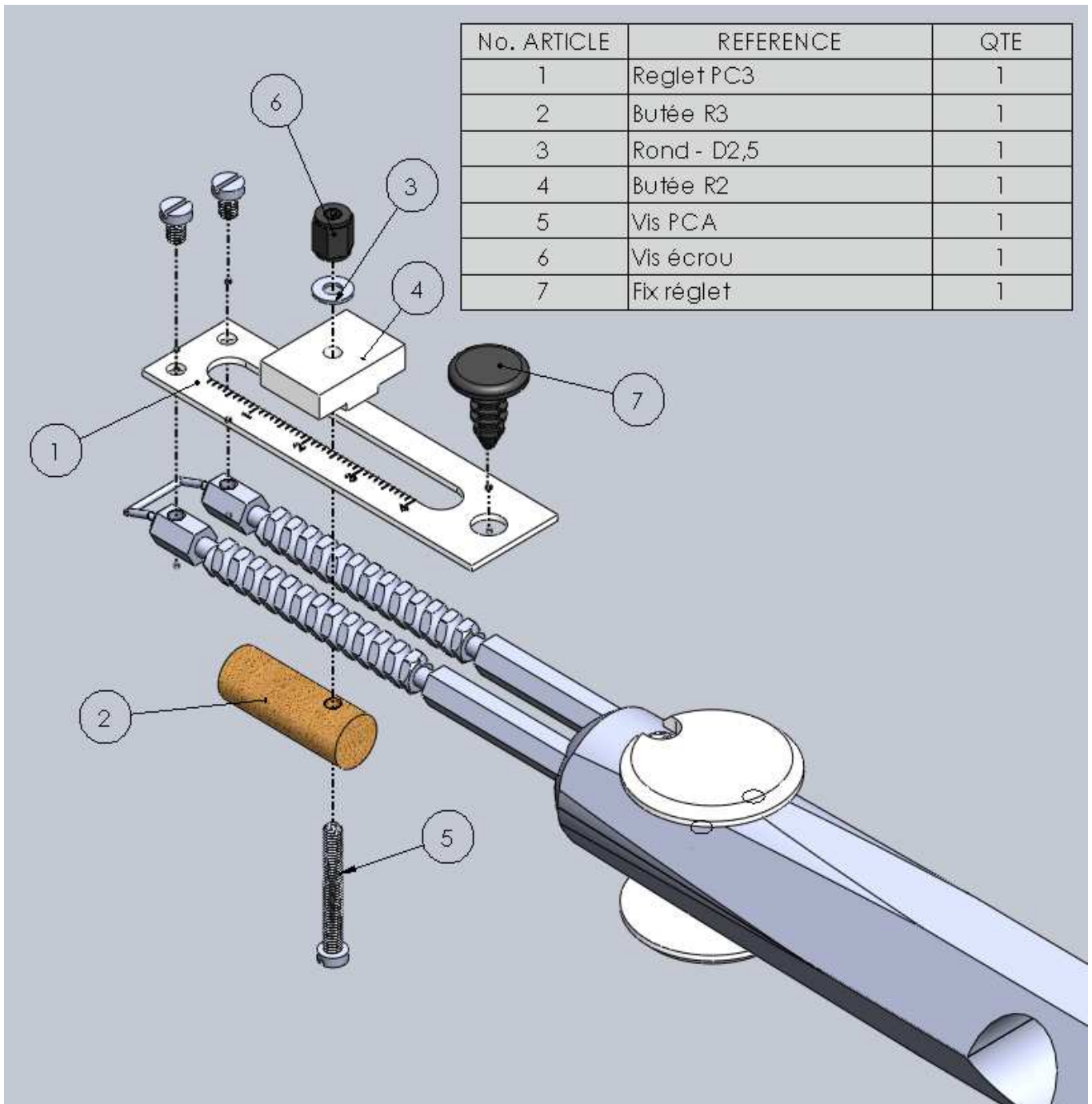

FTM Technologies

7 rue Raymond Poincaré – 92000 Nanterre
Tél 01.40.86.00.09 – Fax. 01.40.86.16.45
info@ftm-technologies.com - www.ftm-technologies.com

Put in operation :

Before starting to use the pliers PC3N, it is necessary to make some adjustments:

- Tight the stop R2 with the screw so as to coincide it with the first stroke.

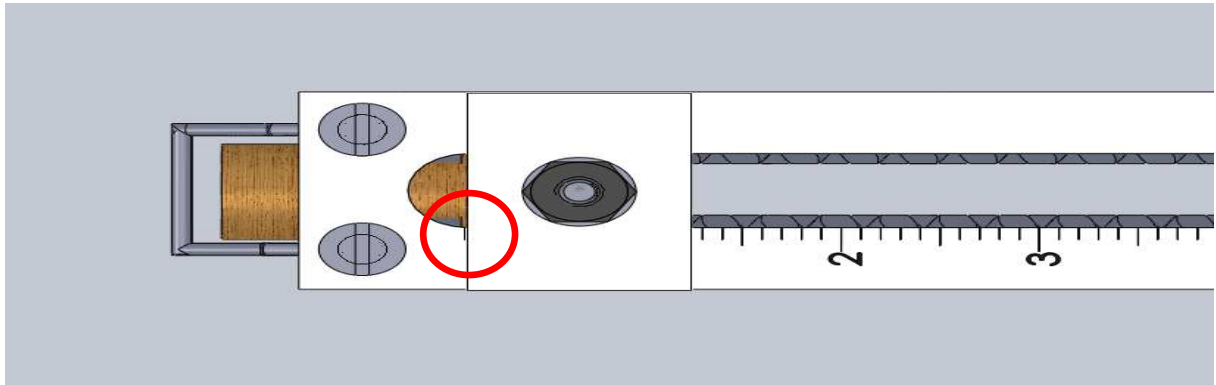

- Tight the pliers
- Apply pressure to the two electrodes to deform these until they are in contact with the stop R3.

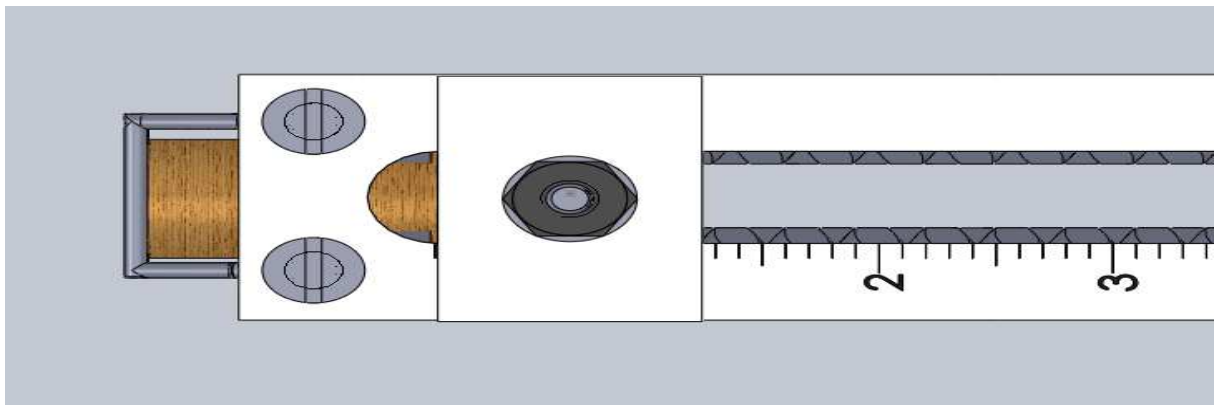
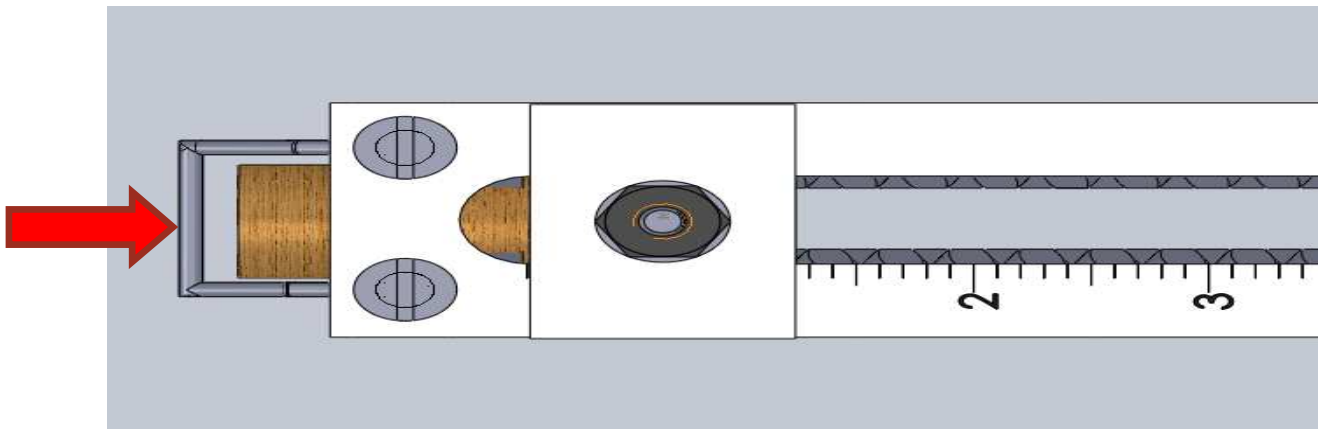

FTM Technologies