



DES CENTRALES DE DESSOUDAGE ALLIANT PERFORMANCE ET ERGONOMIE



*DESOLDERING UNITS COMBINING
PERFORMANCE AND ERGONOMICS*

DESOLDERING UNITS

SEMDATA CONTROL

k Equipped with our new microprocessor-controlled regulation. These desoldering units have been designed to meet the requirements for desoldering multilayer printed circuits. In addition, the desoldering iron's excellent ease of handling, the wide variety of nozzles and a powerful pump guarantee effective and high-quality desoldering with no risk to delicate components and circuit tracks.

The capability of the microprocessor used enables the selected temperature to be regulated very accurately to within $\pm 2^\circ\text{C}$ and the temperature to be set accurately and quickly (displayed in real-time as soon as the potentiometer is turned). The microprocessor provides self-diagnostics of operating faults with a display of codes, and also enables two irons to be simultaneously regulated on the 4602 DC unit together with programming of the following functions:

i First level of programming

and/or **set the desoldering iron to standby** at a temperature of 150°C if it is not used for half an hour;
automatic shut-down of the desoldering iron if it is not used for one hour

Advantages: saving on nozzles, parts which wear and energy - rapid return to the desoldering iron operating temperature - safety

i Second level of programming (independent of the first level)

locking the temperature setting with an access code obtained by a simple rotation of the potentiometer

Advantages: compliance with, and guarantee of, the recommended temperature for the work concerned - protection of components and circuits

The two irons of the 4602 DC unit have independent temperature setting and locking. User friendliness in programming is ensured by the ergonomic nature of the software and by explicit messages as well as by a limited number of commands. The programmed state is recalled every time the device is switched on and all parameters are saved with no time limit after the power is deliberately or accidentally cut off (battery-less operation).

4601 DC1*

100W/24V



L'outil indispensable pour les dessoudages difficiles grâce à sa grande réserve de puissance. - *The indispensable tool for difficult desoldering thanks to its large power reserves.*

4602 DC*

2 x 50W/24V



Idéal pour les travaux de maintenance ou de laboratoire grâce aux fonctions soudage et dessoudage. Choix de l'affichage d'un fer par bouton en façade - *Ideal for maintenance or laboratory work since it provides soldering and desoldering functions. Iron display selected by front panel control.*

TECHNICAL CHARACTERISTICS

DESOLDERING UNITS

- i primary voltage 230V - secondary 24V 50/60 Hz
- i double insulation
- i insulation between primary and secondary : 4000V
- i 0 volt switching
- i temperature controlled by microprocessor from 50°C to 450°C
- i stable temperature (less than 5°C at idle)
- i tip to ground resistance < 2 ohms
- i tip leakage < 2 mV rms
- i reliable grounding of tip
- i pump : 100mbar abs. (-0.9bar)
- i vacuum indication through vacuumeter - except 4600D
- i antistatic and burn-resistant cord

DESOLDERING IRONS

- i power 50 or 100W
- i voltage 24V
- i weight 110 or 120g
- i length 210mm

SOLDERING IRONS

- i power 50W
- i voltage 24V
- i weight 70g
- i length 205mm

All our desoldering units are supplied with a set of nozzles and maintenance kit.

DESOLDERING IRONS



Our irons are light in weight and comfortable to hold in the hand and have a built-in control button. That brings to them more convenient for the operator to use. They are also fitted with an unblockable suction system. They improve precision because of the short distance from hand to the end of the nozzle. All operations involved in their use and maintenance are very simple.

BUSES « HAUT RENDEMENT » « HIGH EFFICIENCY » NOZZLES

Pour fer / For iron 50W

BUSE "HAUT RENDEMENT" "HIGH EFFICIENCY NOZZLES"		REFERENCES Ø 4
Diam. ext. (E)	Diam. int. (I)	Pour fer à dessouder 4701 For desoldering iron 4701 Centrales/Units 4600D - 4601 DC - 4602 DC
1.5 mm	0.6 mm	1506
1.8 mm	0.7 mm	1807
2.0 mm	0.7 mm	2007
2.0 mm	1.0 mm	2010
2.5 mm	1.0 mm	2510
2.5 mm	1.2 mm	2512
2.8 mm	1.5 mm	2815
2.8 mm	1.8 mm	2818
Le jeu de 8 buses / Set of 8 nozzles		2000

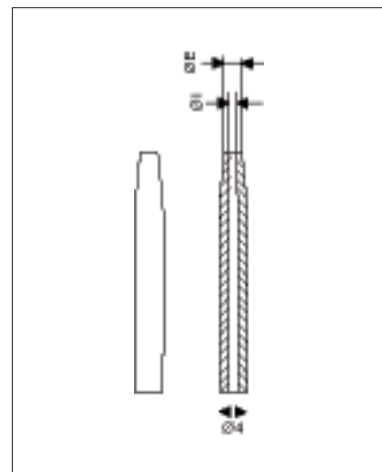

Pour fer / For iron 100W

BUSE "HAUT RENDEMENT" "HIGH EFFICIENCY NOZZLES"		REFERENCES Ø 6
Diam. ext. (E)	Diam. int. (I)	Pour fer à dessouder 14701 For desoldering iron 14701 Centrales/Units 4601DC1
1.5 mm	0.7 mm	11507
2.0 mm	0.8 mm	12008
2.5 mm	1.1 mm	12511
3.0 mm	1.6 mm	13016
3.5 mm	2.0 mm	13520
4 mm	2.5 mm	14025
Le jeu de 6 buses / Set of 6 nozzles		12000

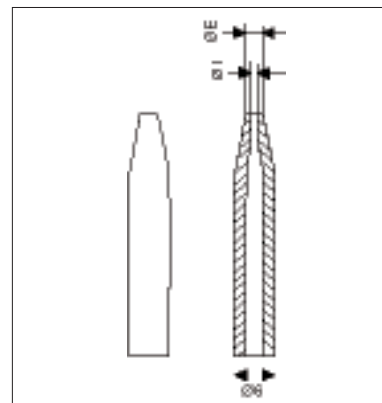

Cette buse a été conçue pour être particulièrement efficace pour les dessoudages intensifs ou difficiles. Un traitement spécial réduisant l'oxydation a été déposé sur la buse. Pour un transfert plus direct de la température toutes les autres barrières thermiques ont été supprimées. Résultat : 20 à 40% de rendement supplémentaire lors de travaux de série.

Designed to be specially efficient for intensive or difficult desoldering works. The nozzles are coated with a plating which reduces oxidation. All the other thermic barriers are suppressed to allow the best heat transfer from the heating element to the tip. It results a 20 to 40% more efficient desoldering and therefore a gain of time.

CONFORME AUX NORMES EUROPEENNES
CONFORMING TO EUROPEAN STANDARDS



Premier fabricant français pour l'industrie électronique

MARCHAND PERNOT



CENTRALES DE DESSOUDAGE / SOUDAGE DESOLDERING / SOLDERING STATIONS

SERIE 4600



Microfer 40W
Soldering microiron



Fer 50W
Soldering iron



Fer à dessouder 50W
Desoldering iron



Fer à dessouder 100W
Desoldering iron



Centrale à dessouder 4601DC
desoldering station



Affichage
display

REFERENCE Code	FER A SOUDER SOLDERING IRON		FER A DESSOUDER DESOLD.IRON		AUTONOME SELF VACUUM	VENTURI	DATACONTROL DISPLAY
	40W I.021.001001	50W I.021.001005	50W I.021.001004	100W I.021.001003			
4600D I.011.001001			X		X		
4600DV I.011.001002			X			X	
4601DC I.011.001003			X		X		X
4601DCV I.011.001006			X			X	X
4601DC1 I.011.001004				X	X		X
4601DC1V I.011.001005				X		X	X
4602DC I.011.001007		X	X		X		X
4602DCV I.011.001008		X	X			X	X
4602MDC I.011.001029	X		X		X		X
4602MDCV I.011.001030	X		X			X	X
4603DC I.011.001026		X		X	X		X
4603DCV I.011.001027		X		X		X	X
4603MDC I.011.001031	X			X	X		X
4603MDCV I.011.001032	X			X		X	X

CONFORME AUX NORMES EUROPEENNES
COMPLYING WITH EUROPEAN STANDARDS

